

Project:	Quantity:
Model #:	Approval:

For Commercial Use Only

PHLM20B-T 20 Quart Gear Driven Commercial Planetary Stand Mixer with Timer



FEATURES

- ▶ Planetary mixer
- ▶ Cast iron construction
- ▶ Heavy-duty use
- ▶ With (0-30) minute timer function
- ▶ Wire bowl safety guard
- ▶ 3-speed control
- ▶ #12 hub for meat grinder attachment
- ▶ Hook, paddle, whip included
- ▶ Push-button controls
- ▶ Floor model usage

The Preline commercial electric planetary mixer is designed for heavy duty use in commercial kitchen. This planetary mixer will come through, however hard the job appears to be. Unique planetary mixing action ensures that all your ingredients are mixed completely so you can prepare your recipes with ease. Whether you're looking to mix dough, cake ingredients, or cookie batters - the Preline commercial planetary stand mixer makes the job super easy and better performance.

• cETLus Listed
• ETL Sanitation Listed
Conforms to UL & NSF Standards



AEON DISTRIBUTORS LTD is a supplier of premium quality commercial cooking, refrigeration, and food preparation equipment. Our aim is simple. Produce industry-leading commercial restaurant equipment at reasonable prices, and back it all up with an easy-to-understand, no-nonsense warranty that people can count on.



AEON DISTRIBUTORS LTD

Tel: +1 868 360 2366 | aeondistributorstt.com | buy@aeondistributorstt.com

AEON Distributors Ltd reserves the right to change specifications without

REV 2023-02

Project:	Quantity:
Model #:	Approval:

For Commercial Use Only

TECHNICAL DATA

DIMENSIONS

Overall Dimensions	24.8"L x 23.2"D x 35"H
Packaging Dimensions	26"L x 25 x 38"H
Capacity	20 qt.
Unit Weight	238 lb.
Shipping Weight	260 lb.

ELECTRICAL

Voltage	110
Hertz	60
Phase	1
Wattage	1100
Plug Type	NEMA 5-15P
Power Cord Length	72"

MIXING

Mixer Type	Planetary
Mixing Heads	1
Transmission Type	Gear Driven
Number of Gear Speed	3
Horsepower	1/2
Speed (RPM)	113 - 400
Control Type	Push Button
Bowl Guard Type	Wire
Bowl Lift Control	Manual
Attachment Hub Type	#12
Dry Dough Capacity	11 lbs.
Dough Capacity	18 lbs.

CONSTRUCTION

Exterior Material	Cast Iron
Accessories Included	Stainless Steel Mixing Bowl Stainless Steel Wire Whisk Aluminum Dough Hook Aluminum Flat Beater
Optional Attachment	Meat Grinder
Feet	Rubber

DIAGRAM

MODEL:PHLM20B-T

MFR MODEL:



NEMA 5-15P

FRONT VIEW

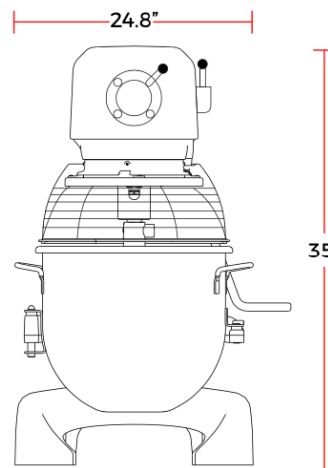

SIDE VIEW

