

Project:	Quantity:
Model #:	Approval:

*For Commercial Use Only*

## MC32 #32 HUB 2 HP Meat Grinder



### FEATURES

- Stainless steel construction
- Forward and reverse switch
- Gear-driven transmission
- Equipped with a micro safety switch
- Designed for commercial use
- 5mm, and 6mm extruder plate
- Plastic food pusher
- #32 Hub attachment
- 661 lbs/hour production capacity

This Preline MC meat grinder is an ideal piece of equipment for small butcher shops, delis, and restaurants. This professional meat chopper facilitates prompt and efficient breakdown of sausage, beef, wild game, and other meats to save time and labor in your establishment. With a powerful motor and a sturdy stainless steel construction, this unit will withstand the rigors of daily, hard use. Maximize your meat processing capabilities and get more value for money with a Preline industrial meat grinder.

• CE Certified



---

AEON DISTRIBUTORS LTD is a supplier of premium quality commercial cooking, refrigeration, and food preparation equipment. Our aim is simple. Produce industry-leading commercial restaurant equipment at reasonable prices, and back it all up with an easy-to-understand, no-nonsense warranty that people can count on.



**AEON DISTRIBUTORS LTD**

Tel: +1 868 360 2366 | [aeondistributorstt.com](http://aeondistributorstt.com) | [buy@aeondistributorstt.com](mailto:buy@aeondistributorstt.com)

REV 2023-02

AEON Distributors Ltd reserves the right to change specifications without

Project:	Quantity:
Model #:	Approval:

For Commercial Use Only

## TECHNICAL DATA

### DIMENSIONS

Overall Dimensions	13.5"L x 19"D x 22.75"H
Packaging Dimensions	15"L x 24"W x 25"H
Unit Weight	93 lb.
Shipping Weight	100 lb.

### ELECTRICAL

Voltage	110
Hertz	60
Phase	1
Wattage	1800
Plug Type	NEMA 5-15P
Power Cord Length	48"

### GRINDING

Head Size	#32
Throat Opening	2"
Production Capacity	661 lbs./hr
Extruder Disc/Plate	1/4" (6mm), 5/16" (8mm)
Horsepower	2
RPM	230

### CONSTRUCTION

Exterior Material	Stainless Steel
Features	Forward and Reverse Switch Micro Safety Switch Gear-Driven
Accessories	Feed Pan Feed Stomper Collecting Tray Grinding Plates

## DIAGRAM

MODEL: MC32

MFR MODEL:



### FRONT VIEW

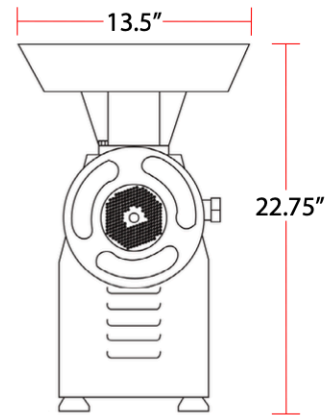

### SIDE VIEW

